

SPARE PARTS LIST

PAGE 1

MODEL NO. AN510H

ITEM	PART NO.	DESCRIPTION	QTY	NOTE
001	266233-9	HEX. SOCKET HEAD BOLT M5x12	1	
002	267343-5	FLAT WASHER 5 AN711H	1	
003	419764-9	EXHAUST COVER AN510H	1	
004	413106-9	INLET FILTER AN510H	1	
005	419763-1	COVER SEAL AN510H	1	
006	266369-4	HEX. SOCKET HEAD BOLT M5x20	4	
007	318252-2	TOP CAP AN510H	1	
008	234055-5	COMPRESSION SPRING 27 AN510H	1	
009	213021-5	O-gyuru 5 LS080/0810/LS1013	1	
010	213393-8	O RING 23	1	
011	213458-6	O-gyuru 34 HP200/HP2010/N/DA3	1	
012	419770-4	HEAD VALVE	1	
013	213510-0	O-gyuru 36 213510-0	1	
014	331744-4	HEAD VALVE GUIDE AN510H	1	
015	213561-3	O Ring 42	1	
016	194736-2	AIR LEAK REPAIR SET INC. 10,11,13,15,110	1	
017	267344-3	FLAT WASHER 18 AN510H	1	
018	421993-2	REAR CUSHION AN510H	1	
019	213282-7	O RING 17 AN510H	1	
020	165458-1	DRIVER AN510H	1	
021	135135-9	DRIVER INC. 19,20	1	
022	421994-0	Valve Set AN510H	1	
023	331743-6	Cylinder Stay AN510H	1	
024	331742-8	CYLINDER AN510H	1	
025	213462-5	O RING 33	1	
026	213405-7	O-gyuru 26, 1/2c-os Dugókulcsh	1	
027	162249-1	Top cap gasket AN510H	1	
028	866113-5	NAME PLATE AN510H	1	
029	819333-0	MAKITA logo label R	1	
031	819334-8	MAKITA logo label L	1	
033	188650-2	HOUSING SET AN510H INC. 29,31	1	
034	421992-4	CUSHION FRONT AN510H	1	
035	213491-8	O RING 31 AN510H	1	
036	213034-6	O RING 3	1	
037	158171-8	DRIVER GUIDE AN510H	1	
038	266369-4	HEX. SOCKET HEAD BOLT M5x20	4	
039	951078-5	SPRING PIN AN711H/AN620H/510H	1	
040	951078-5	SPRING PIN AN711H/AN620H/510H	1	
041	951078-5	SPRING PIN AN711H/AN620H/510H	1	
042	951069-6	Hasított Csapszeg 3-20 (AN5010)	1	
043	413105-1	INLET FILTER AN711H/AN510H	1	
044	213521-5	O RING 36	1	
045	318108-9	INLET CAP	1	
046	286280-4	CAP 9	1	
047	243105-5	One touch joint	1	
048	265570-8	HEX.SOCK.HEAD BOLT M5x28 AN711	1	
049	267343-5	FLAT WASHER 5 AN711H	1	
050	419768-1	MAGAZINE	1	
051	419767-3	Change Sleeve	1	
052	216001-0	Acélgolyó 3,5 216001-0*	1	
053	233492-0	COMPRESSION SPRING 2 AN711H	1	
054	268169-8	PIN 2.5	1	
055	268167-2	PIN 2.5	1	
056	419766-5	CHANGE PLATE	1	
057	233505-7	TORSION SPRING 7 AN711H	1	

SPARE PARTS LIST

PAGE 2

MODEL NO. AN510H

ITEM	PART NO.	DESCRIPTION	QTY	NOTE
058	961105-0	Seeger-gyuru S-25 961105-0	1	
059	419765-7	CHANGE SHAFT	1	
060	158916-4	MAGAZINE CAP COMPLETE	1	
061	259042-3	STOP RING E-3	1	
062	268171-1	PIN 4	1	
063	135257-5	MAGAZINE ASSY INC. 50-62	1	
064	162255-6	HOOK BASE	1	
065	419843-3	HOOK AN510H	1	
066	265176-2	PAN.HD.SCREW M5x22	1	
067	931202-6	Hatlapú anya M5 931202-6	1	
068	962101-1	RETAINING RING R-21 AN510H	1	
069	345777-3	CUP WASHER AN510H	1	
070	233493-8	COMPRESSION SPRING 6 AN510H	1	
071	233494-6	COMPRESSION SPRING 8 AN510H	1	
072	262121-8	RUBBER RING 13 AN510H	1	
073	213154-6	O RING 14	1	
074	324750-6	PISTON AN510H	1	
075	213007-9	O-gyuru 8 5014NB/AN7000	1	
076	262120-0	URETHANE RING 6	1	
077	310189-9	DOOR AN510H	1	
078	262120-0	URETHANE RING 6	1	
079	265903-7	HEX. SOCKET HEAD BOLT M5x12	1	
080	419762-3	CONTACT ARM COVER AN510H	1	
081	231652-8	TORSION SPRING 6 AN510H	1	
082	310116-6	FEEDING CLAW AN510H	1	
083	256463-0	Shoulder Pin 3-4 AN510H	1	
084	268170-3	PIN 4 AN510H	1	
085	268183-4	PIN 3 AN510H	1	
086	162247-5	LOCK LEVER AN620H/AN510H	1	
087	234013-1	COMPRESSION SPRING 5 AN510H	1	
088	233133-8	COMPRESSION SPRING 4 AN510H	1	
089	344995-0	CHECK CLAW AN510H	1	
090	233133-8	COMPRESSION SPRING 4 AN510H	1	
091	311998-9	NAIL HOLDER AN510H	1	
092	233133-8	COMPRESSION SPRING 4 AN510H	1	
093	311997-1	ARM AN510H	1	
094	419761-5	DOOR COVER AN510H	1	
095	265903-7	HEX. SOCKET HEAD BOLT M5x12	1	
096	421418-6	RUBBER PIN 9.5	1	
097	413107-7	MAGAZINE COVER AN510H	1	
098	213233-0	O RING 15	1	
099	213275-4	O gyuru 18	1	
100	419732-2	TRIGGER VALVE GUIDE AN510H	1	
101	213968-3	O RING 7	2	
102	419733-0	PILOT VALVE AN610H	1	
103	213185-5	O RING 12.5	1	
104	233485-7	COMPRESSION SPRING 4 AN510H	1	
105	213034-6	O RING 3	1	
106	324743-3	TRIGGER VALVE STEM	1	
107	213979-8	O RING 3	2	
108	213275-4	O gyuru 18	1	
109	331741-0	TRIGGER VALVE CASE	1	
110	194736-2	AIR LEAK REPAIR SET INC. 16,98,99,101,103,105,107, INC. 108	1	
111	233501-5	TORSION SPRING 5	1	
112	310199-6	STOPPER PLATE	1	

SPARE PARTS LIST

MODEL NO. AN510H

ITEM	PART NO.	DESCRIPTION	QTY	NOTE
113	*****	*****	***	*****
114	310310-0	LEVER	1	
115	216024-8	STEEL BALL 4	1	
116	233490-4	COMPRESSION SPRING 2	1	
117	419743-7	SPRING COVER	1	
118	268168-0	PIN 3	1	
119	268168-0	PIN 3	1	
120	951007-8	SPRING PIN 2-12	1	
121	310294-2	TRIGGER	1	
122	231699-2	TORSION SPRING 4	1	
123	310196-2	TRIP LEVER	1	
124	310198-8	LEVER	1	
125	233503-1	TORSION SPRING 4	1	
126	419844-1	TRIGGER	1	
127	135231-3	TRIGGER	1	
		INC. 111-126		
128	310293-4	CHANGE ROD AN711H	1	
129	234012-3	COMPRESSION SPRING 6 AN510H	1	
130	951010-9	SPRING PIN 2-14	1	
131	310201-5	Adjuster Piece	1	
132	345775-7	SLIDE PLATE	1	
133	310234-0	UPPER YORK	1	
134	324745-9	ADJUSTING SHAFT	1	
135	233491-2	COMPRESSION SPRING 2	1	
136	216031-1	STEEL BALL 2.3	1	
137	158747-1	Adjuster	1	
140	951010-9	SPRING PIN 2-14	1	
141	135232-1	ADJUSTER	1	
		INC. 130-137,140		
142	262120-0	URETHANE RING 6	1	
143	324751-4	Arm AN510H	1	
144	262128-4	URETHANE RING 4 AN510H	1	
145	310240-5	CONTACT TOP AN510H	1	
A01	195246-2	SAFETY GOGGLE	1	
A02	194381-3	OIL SUPPLY	1	
A03	421996-6	BOARD ADAPTER AN510H	1	
A04	421997-4	FLOOR ADAPTER AN510H	1	
A05	824793-3	PLASTIC CARRYING CASE AN510H	1	

SERVICE DRAWING

MODEL NO. AN510H

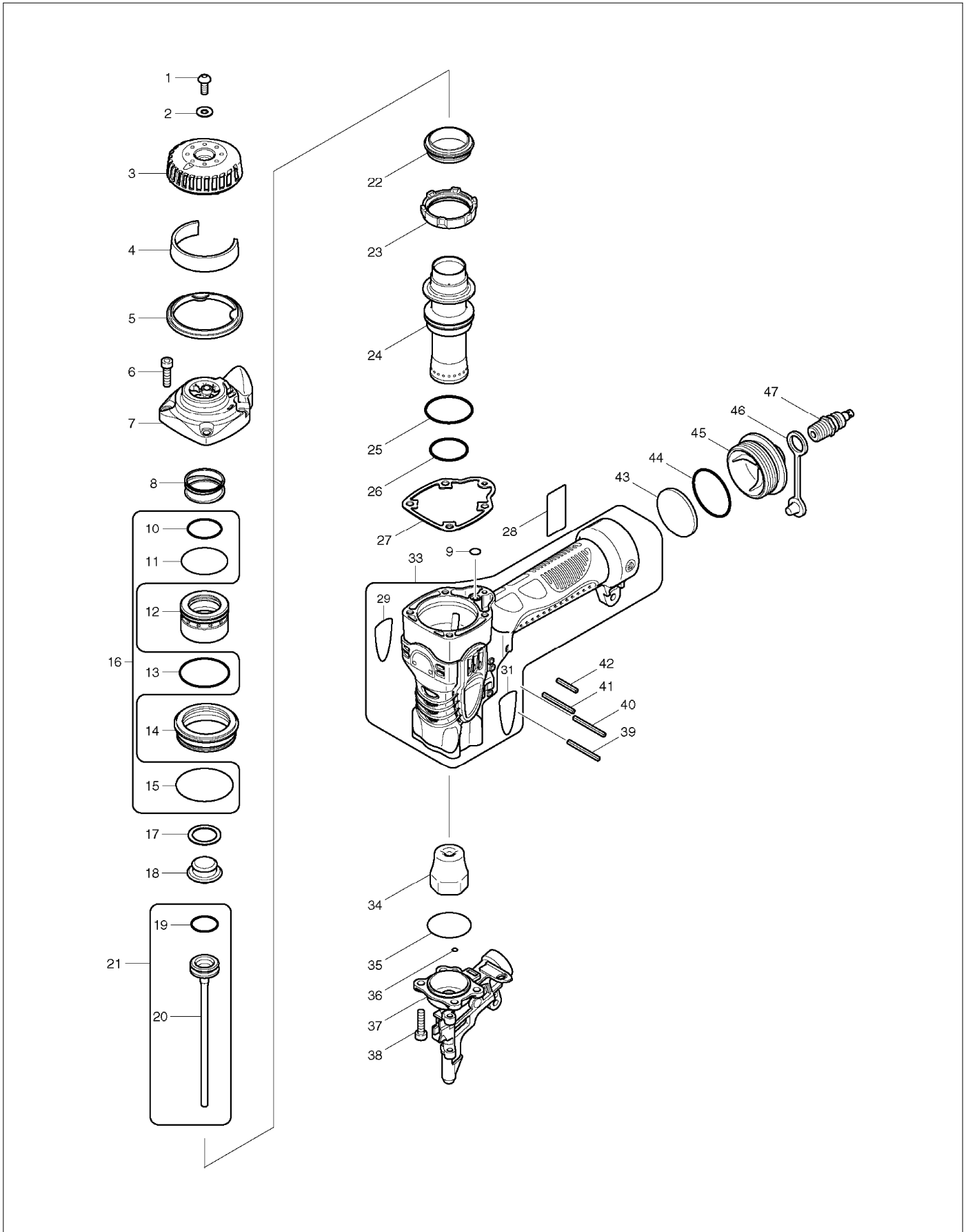

SERVICE DRAWING

MODEL NO. AN510H

